

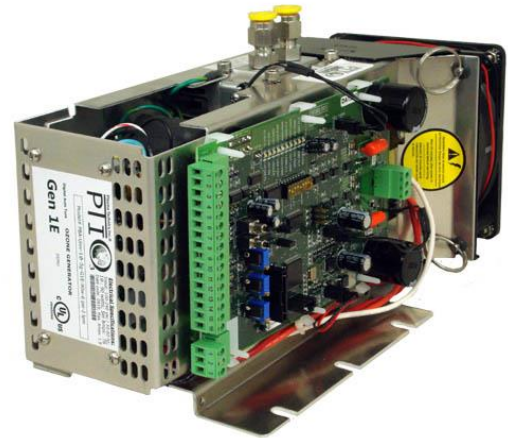

SPECIALISTS IN OZONE TECHNOLOGY

7g @ 5% Wt. O₂

3g @ .5% Wt. **AIR**



ELECTRICAL RATINGS

Voltage	1Φ 120 / 240 VAC
Current	1.1 / 0.7 Amps
Frequency	50 / 60 Hz
Power	87 Watts

PERFORMANCE

Model	Pressure	Flow	Std. Flow
G1E	6 psi	2 LPM	2.15 SLPM
Heat Load			297 BTU/hr
Cooling			Fan cooled

MAXIMUMS

Ambient Temperature	120 °F
Block Temperature	190 °F
Devices Temperature	200 °F
Voltage	240 VAC
Pressure	100 psi

OTHER SPECIFICATIONS

	SI	Metric
Weight	7.6 lbs.	3.45 kg
Length	11.65 in.	295.6 mm
Width	7.09 in.	180.1 mm
Height	5.46 in.	138.7 mm

- Microprocessor controlled
- UL Listed
- Microchannel design
- Precise ozone control

SAFE EFFICIENT
SILENT ADVANCED

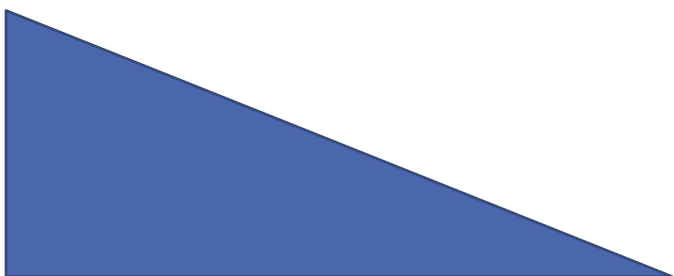

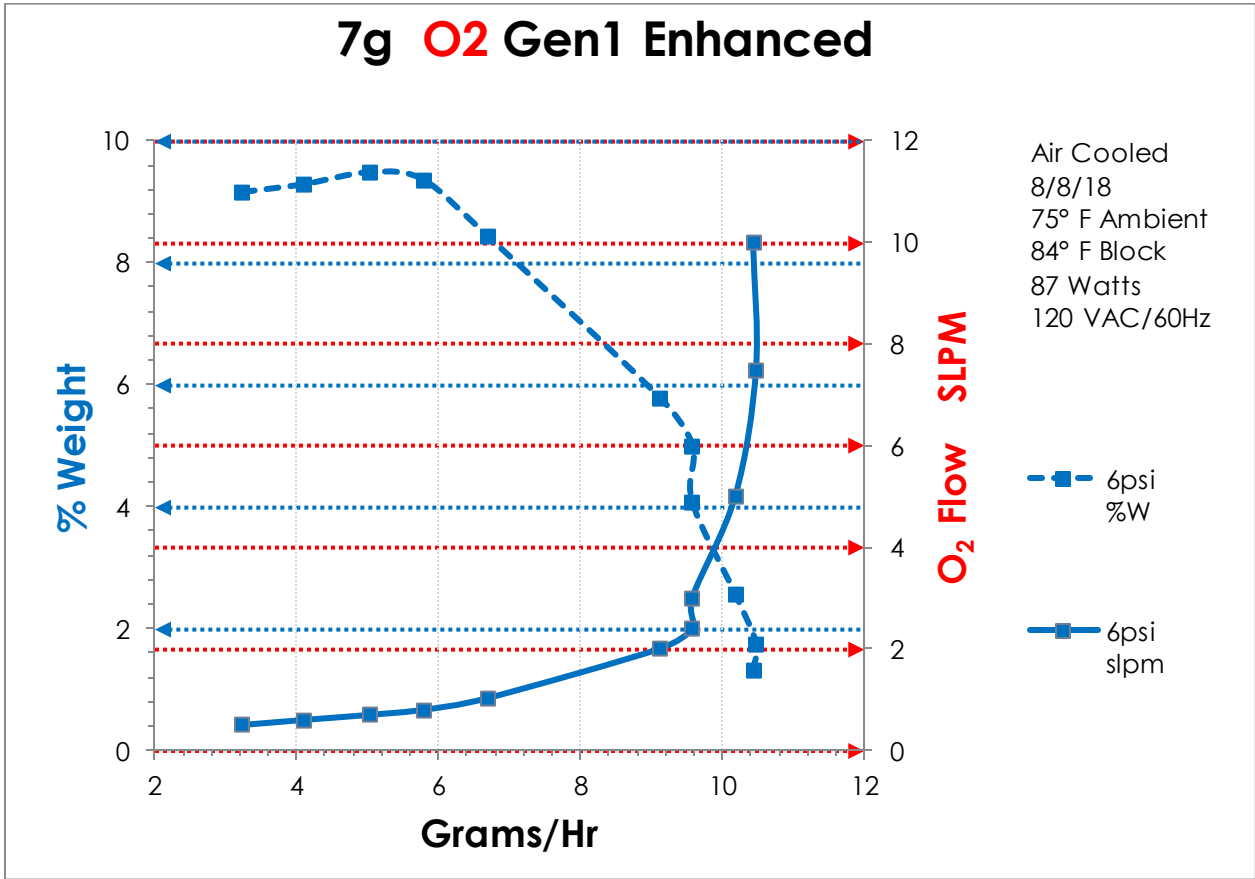

PRELIMINARY 3g/hr @ .5%WT

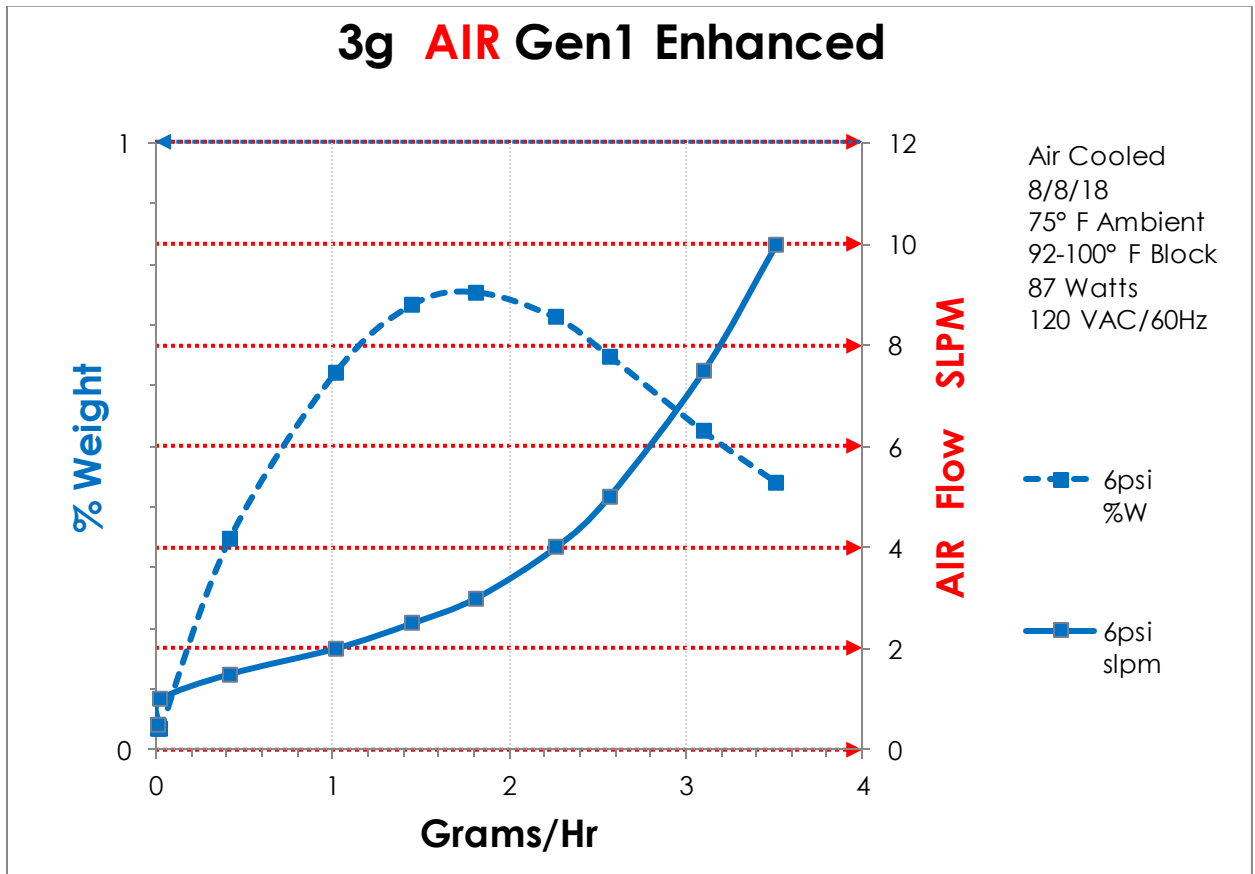

Alternate Bracket Mount

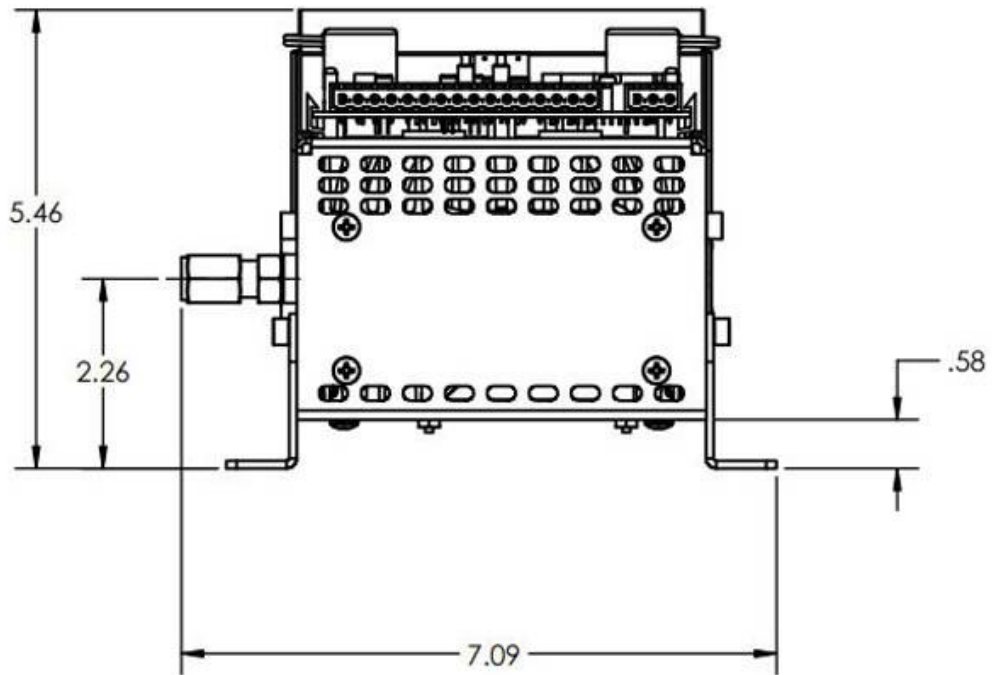
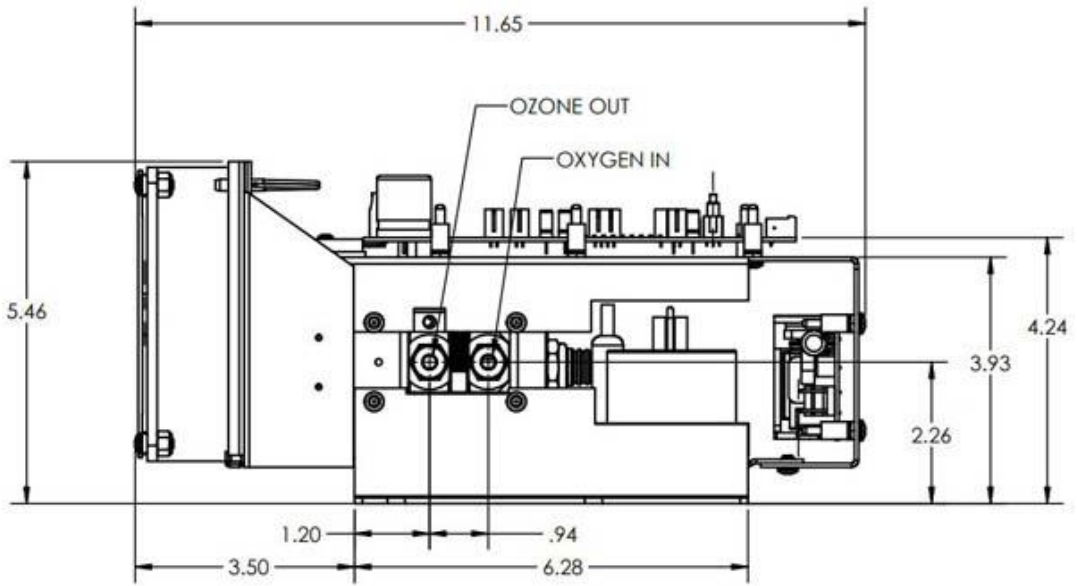

Standard Bracket Mount

